



*Rewarding Learning*  
**ADVANCED SUBSIDIARY (AS)**  
**General Certificate of Education**

Centre Number

--	--	--	--	--

Candidate Number

--	--	--	--

# Technology and Design

Assessment Unit AS 1  
*assessing*  
 Systems and Control or  
 Product Design



STE12

## [STE12] Assessment

### TIME

1 hour.

### Assessment Level of Control:

Tick the relevant box (✓)

Controlled Conditions	
Other	

### INSTRUCTIONS TO CANDIDATES

Write your Centre Number and Candidate Number in the spaces provided at the top of this page.

Answer **both** questions in **either** Section A, B or C.

### INFORMATION FOR CANDIDATES

The total mark for this paper is 40.

Figures in brackets printed down the right-hand side of pages indicate the marks awarded to each question or part question.

For Examiner's use only	
Question Number	Marks
1	
2	
3	
4	
5	
6	

<b>Total Marks</b>	
--------------------	--

## Section A

### Electronic and Microelectronic Control Systems

Answer **both** questions in this section.

- 1 (a) A partially complete circuit consisting of a microswitch arrangement and a pull down resistor is shown in **Fig. 1**.

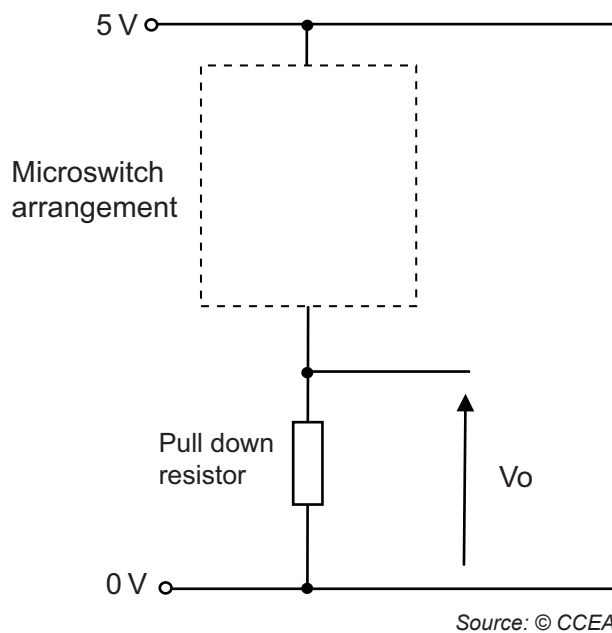

**Fig. 1**

- (i) Microswitches have a specific main characteristic. State **one** main characteristic associated with a microswitch.

\_\_\_\_\_

\_\_\_\_\_ [1]

- (ii) The microswitch arrangement in **Fig. 1** consists of 2 SPST microswitches that are connected to achieve **AND** logic when operated. Using appropriate symbols, complete the circuit shown in **Fig. 1** so that  $V_o$  is 5V when the 2 SPST microswitches are operated. [2]

- (iii) With reference to  $V_o$  in **Fig. 1** explain the purpose of a pull down resistor.

\_\_\_\_\_

\_\_\_\_\_ [2]

Examiner Only	
Marks	Remark

- (b) The output  $V_o$  from **Fig. 1** is to be used to switch an SPDT relay using the transistor arrangement shown in **Fig. 2**. The transistor has a gain ( $h_{fe}$ ) of 60 and the relay coil has a resistance of 8 Ohms.

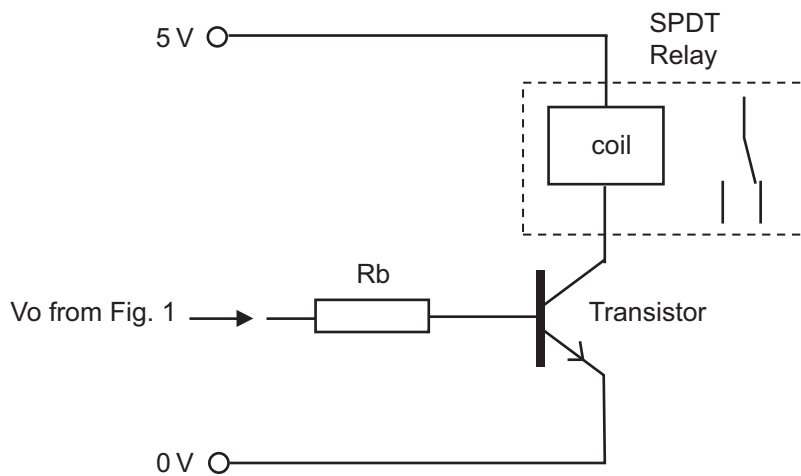

Source: © CCEA

**Fig. 2**

- (i) Calculate the value for the base resistor,  $R_b$ , for the transistor in **Fig. 2** if the base emitter voltage ( $V_{be}$ ) is 0.6V. Assume that the voltage  $V_o$  from **Fig. 1** is 5V and the transistor has a suitable  $I_c$  (max).

Value for  $R_b = \underline{\hspace{2cm}} \Omega$  [4]

- (ii) Calculate the power dissipated by the relay coil in **Fig. 2** when it is operational.

Power dissipated =  $\underline{\hspace{2cm}}$  W [2]

Examiner Only	
Marks	Remark

Examiner Only	
Marks	Remark

(iii) The relay coil in **Fig. 2** is an inductive load and it has been suggested that a diode should be added to the circuit in order to protect the transistor. Draw the symbol for a diode on **Fig. 2** showing where it should be connected. [1]

(iv) Explain how a diode operates to protect a transistor from an inductive load.  
 \_\_\_\_\_  
 \_\_\_\_\_  
 \_\_\_\_\_ [2]

(v) The circuit shown in **Fig. 2** is to be used to control two 12V bulbs. A red bulb is to illuminate when the relay is operated and a green bulb when it is not operated. Complete the relay part of the circuit on **Fig. 3** below to show how this could be achieved.

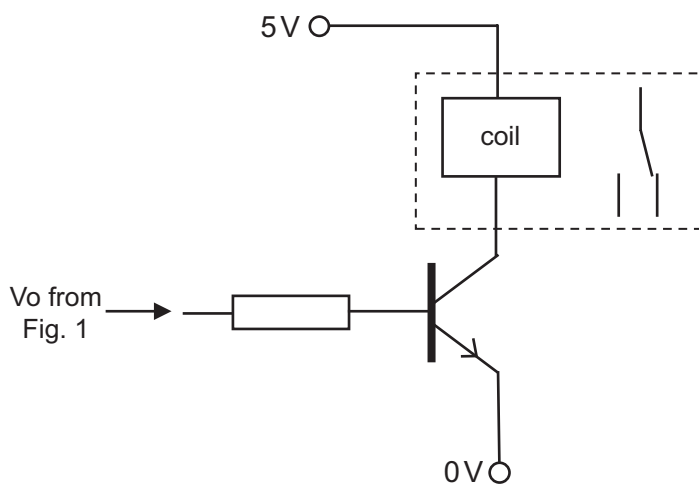

Fig. 3

Source: © CCEA

[3]

(vi) The circuit shown in **Fig. 3** is to be modified to achieve a latching action when the transistor switches on. Suggest how this could be achieved and explain the operation of your modification to include a description of how the circuit could be reset.

\_\_\_\_\_

\_\_\_\_\_

\_\_\_\_\_

\_\_\_\_\_

\_\_\_\_\_ [3]

**BLANK PAGE**

**(Questions continue overleaf)**

- 2 (a) Logic gates are used in a wide range of electronic circuits. Complete the circuit symbol for gate A and the truth table for gate B in Fig. 4.



input A	input B	output Q
0	0	0
0	1	0
1	0	0
1	1	1

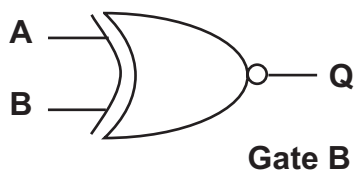

input A	input B	output Q
0	0	
0	1	
1	0	
1	1	

Fig. 4

[2]

- (b) Logic gates can be combined to make an SR flip flop circuit as shown in Fig. 5. The circuit is to be used for a simple panic alarm where a push to break (PTB) switch is pressed to activate the alarm and another PTB switch is pressed to deactivate the alarm. An LED indicates when the alarm has been deactivated.

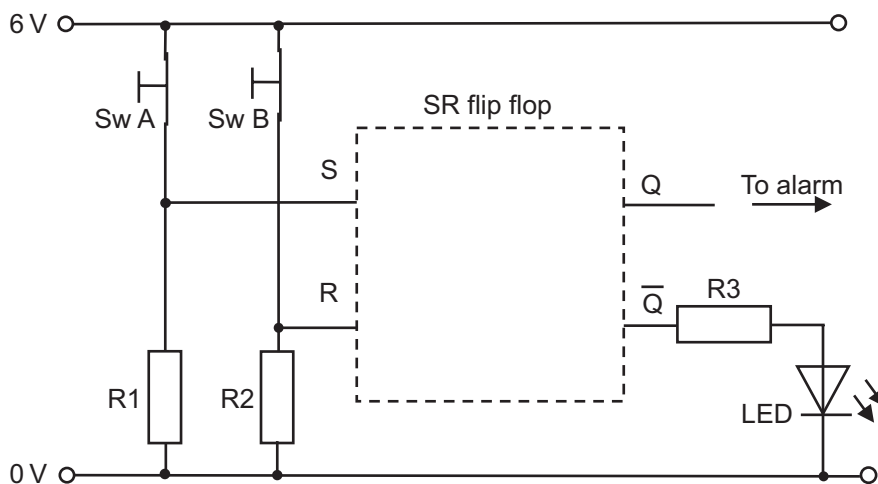

Source: © CCEA

Fig. 5

Examiner Only	
Marks	Remark

- (i) Draw the arrangement of logic gates (inside the dashed box on **Fig. 5**) required to make an SR flip flop. Show the connections to S, R, Q and  $\bar{Q}$ . [2]
- (ii) The table shown in **Fig. 6** is an incomplete truth table for the operation of the SR flip flop circuit shown in **Fig. 5**. Complete the three missing logic states.

Sw A pressed?	Sw B pressed?	Logic state at S	Logic state at R	Q logic state	$\bar{Q}$ logic state
no	no	1	1	0	1
yes	no	0	1		0
no	no	1	1	1	
no	yes		0	0	1

Fig. 6

[3]

- (iii) The resistor R3 shown in **Fig. 5** has been selected from the E12 series. Explain what the E12 series is when referring to resistors.

---



---



---



---

[2]

Examiner Only	
Marks	Remark

- (c) (i) The Q output from the SR flip flop shown in **Fig. 5** is to be used to operate a buzzer. The buzzer in turn is driven by an astable circuit based on a 555 timer. On the axes shown in **Fig. 7**, sketch a graph to show the output from an astable timer with a time period of 0.8 seconds and a mark/space ratio of **3:1** (assume the astable output is 6 V).

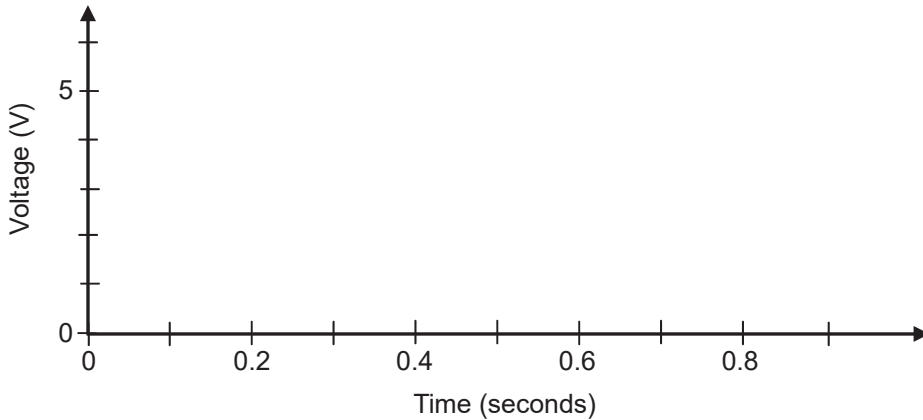

**Fig. 7**

[2]

- (ii) **Fig. 8** shows the incomplete astable timer circuit used to control the buzzer. Complete the circuit diagram by adding any resistors and an appropriate capacitor required, showing how they are connected to the discharge, trigger and threshold pins.

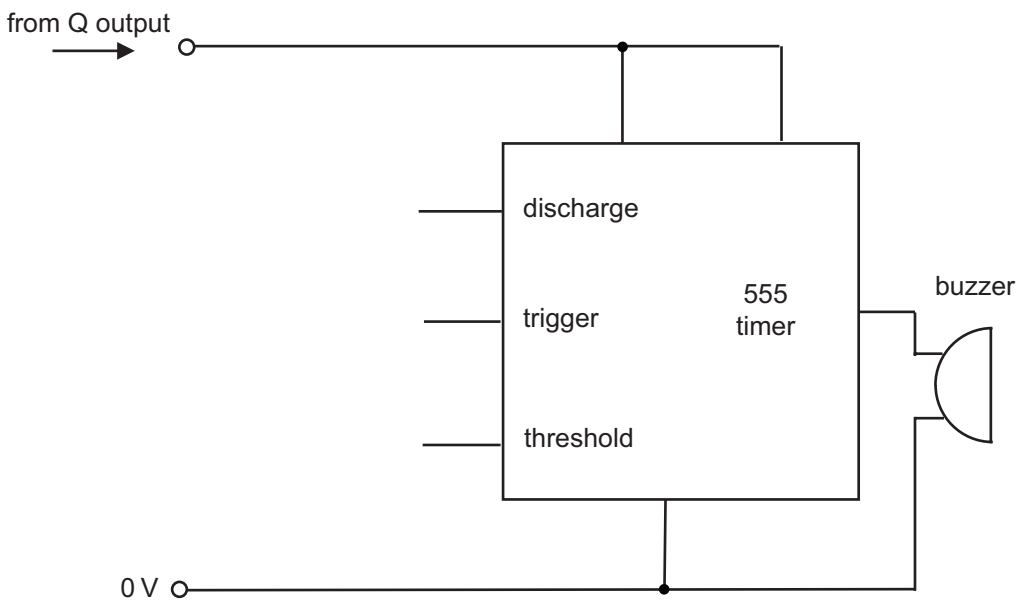

Source: © CCEA

**Fig. 8**

[3]

Examiner Only	
Marks	Remark



## Section B

### Mechanical and Pneumatic Control Systems

Answer **both** questions in this section.

- 3 Fig. 9 shows an incomplete system which may be used to fill bags with plastic granules.

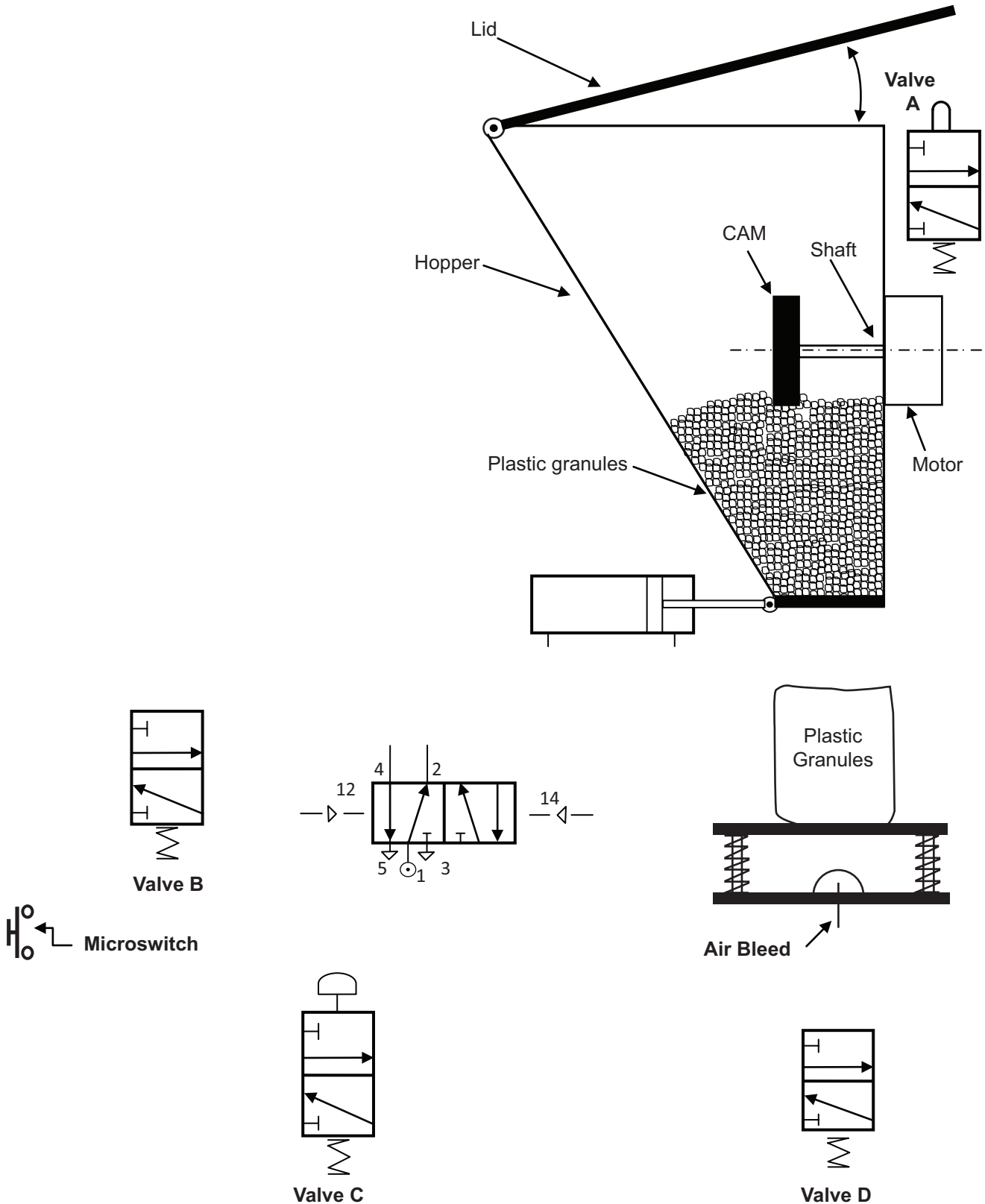

Fig. 9  
10

- (a) (i) In order to move the plastic granules in the hopper shown in Fig. 9, a pear-shaped or heart-shaped cam is to be used. The cam will be attached to the shaft and driven by a motor. On Fig. 10 below, using the shafts and centre lines as a reference, sketch the profile for a pear-shaped cam and for a heart-shaped cam. [2]

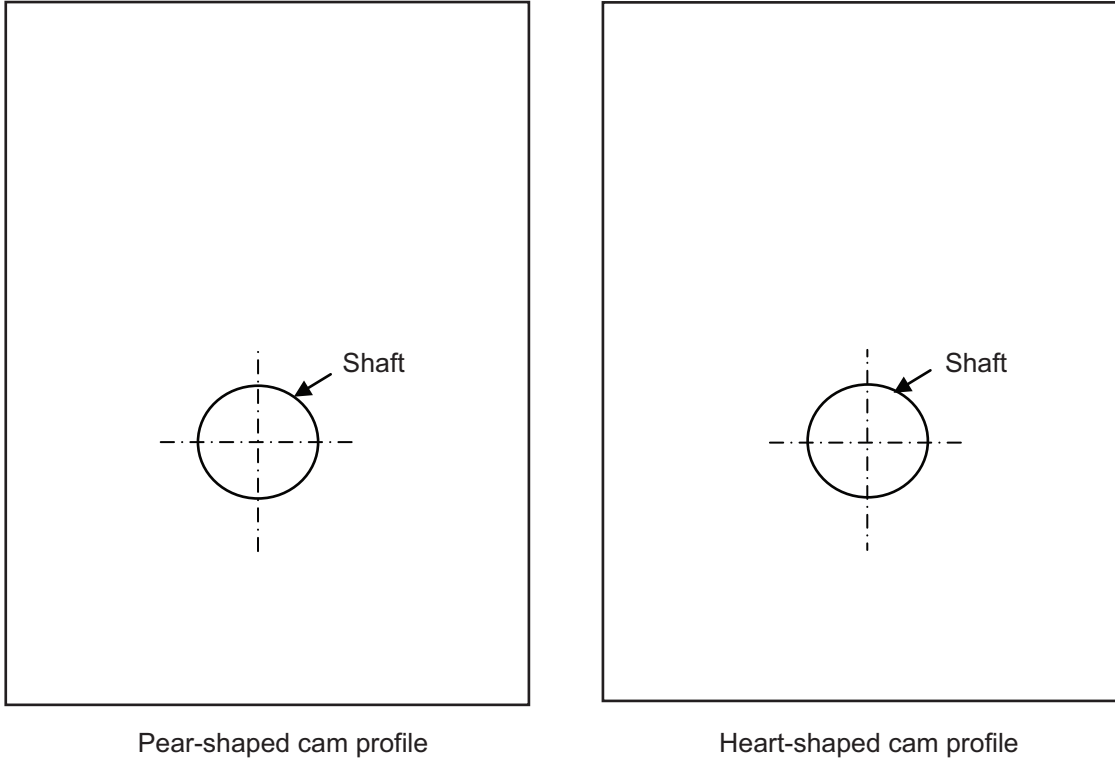

Fig. 10

- (ii) When designing the profile or shape of a cam, the terms rise, dwell and stroke length are important to consider.

With reference to cams, outline what is meant by the term rise.

\_\_\_\_\_ [1]

With reference to cams, outline what is meant by the term dwell.

\_\_\_\_\_ [1]

With reference to cams, outline what is meant by the term stroke length.

\_\_\_\_\_ [1]

Examiner Only	
Marks	Remark



- 4 **Fig. 11** shows an incomplete prototype mechanical system used to test the fabric on a trampoline. The system is driven from a motor through a series of gears and pulleys and will lift and lower a weight to impact on the surface of the trampoline. The trampoline will rotate using a pneumatic circuit.

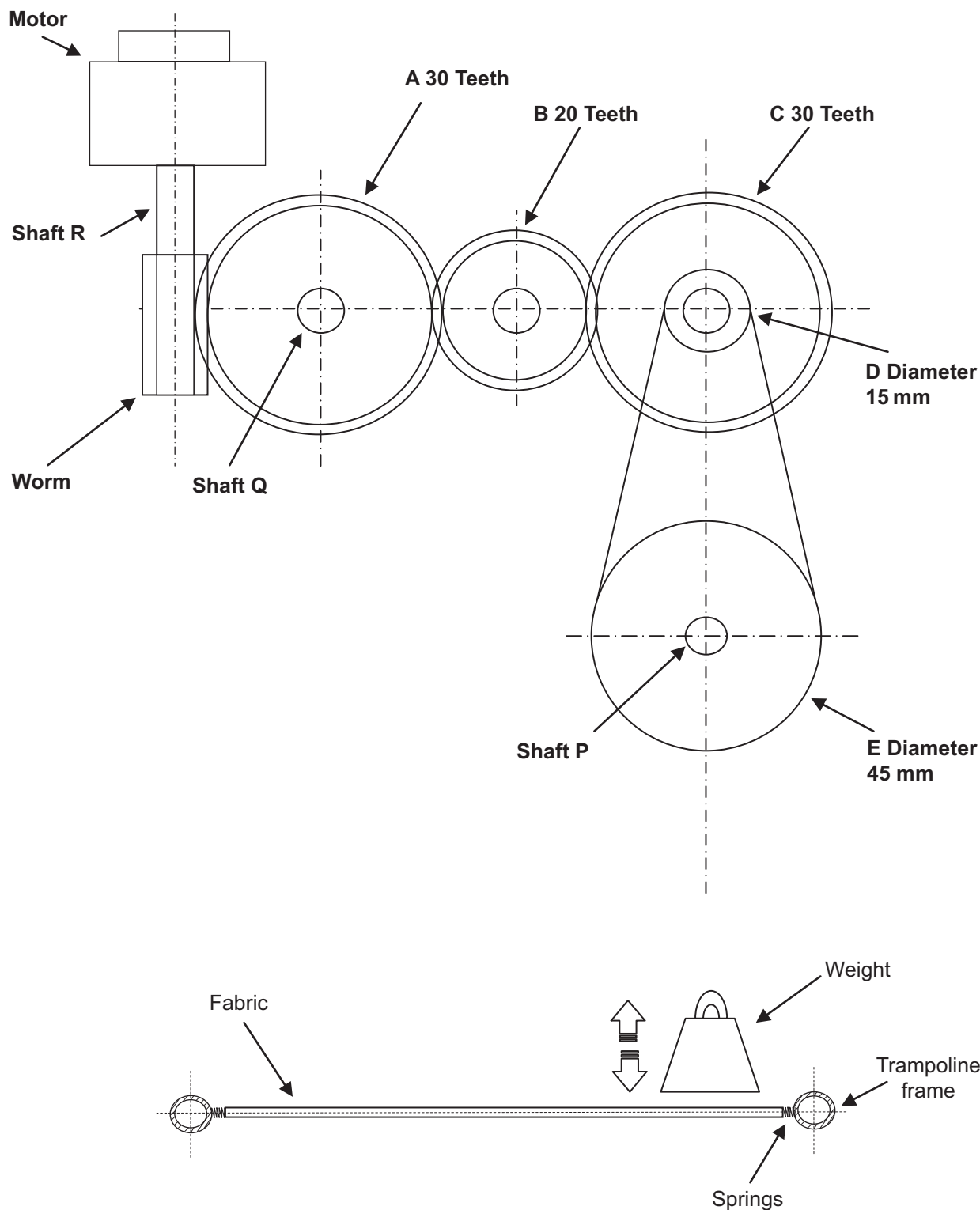

**Not to Scale**

**Fig. 11**

- (a) (i) Using an annotated sketch, name and draw a system on **Fig. 12** below which would convert the rotary motion of shaft **P** into a reciprocating motion of the weight in order to test the fabric.

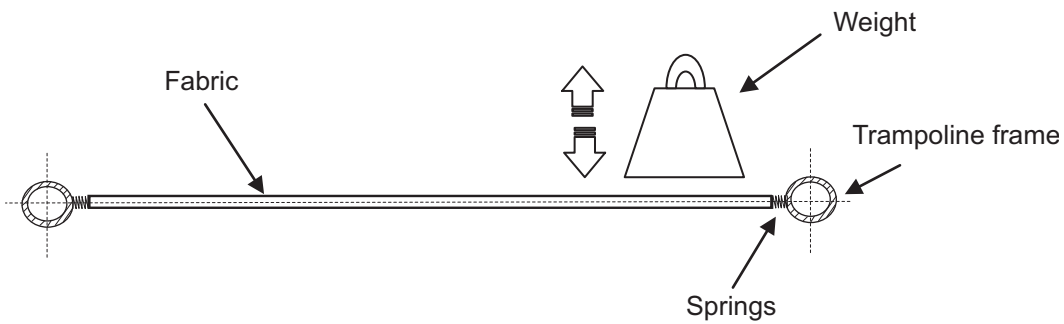
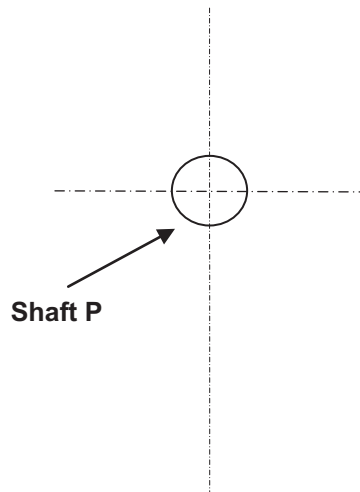

**Fig. 12**

[2]

- (ii) Calculate the output speed of the motor in **Fig. 11** if **E** rotates at 60 rev/min.  
Show your working out clearly.

Output speed: \_\_\_\_\_ [5]

Examiner Only	
Marks	Remark

- (iii) The gears and pulleys in **Fig. 11** are to be changed to give an overall velocity ratio of 20. Calculate the maximum load of the weight which could be moved using an effort of 8 N if the efficiency of the system is 80%. Ignore friction. Show your working out clearly.

Maximum load: \_\_\_\_\_ [4]

- (iv) With reference to **Fig. 11**, briefly outline **two** main reasons why a vee belt would be used in preference to a flat belt to transmit the drive from pulley D to pulley E.

1. \_\_\_\_\_  
 \_\_\_\_\_ [1]

2. \_\_\_\_\_  
 \_\_\_\_\_ [1]

- (b) (i) The system shown in **Fig. 11** uses pneumatics to rotate the trampoline frame.

Briefly outline **one** main safety issue which arises when using pneumatics, and briefly outline **one** main procedure which could minimise this issue.

Safety issue \_\_\_\_\_  
 \_\_\_\_\_ [1]

Procedure \_\_\_\_\_  
 \_\_\_\_\_ [1]

Examiner Only	
Marks	Remark

(ii) **Fig. 13** shows an incomplete pneumatic circuit which is to be used to rotate the trampoline frame. The DAC outstrokes and the one way trip mechanism rotates the trampoline frame in steps.

Complete the circuit diagram adding any additional components to enable:

- the double acting cylinder to repeatedly outstroke slowly and then instroke slowly following a time delay (only reservoirs and flow regulators can be used).
- the instroke or outstroke movement of the DAC to be stopped at any time using valve A.

[5]

Examiner Only	
Marks	Remark

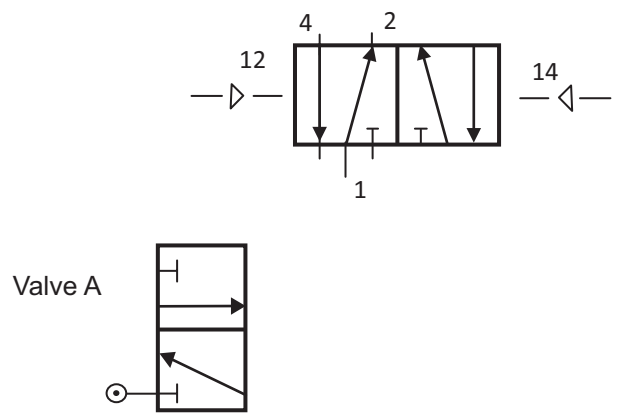
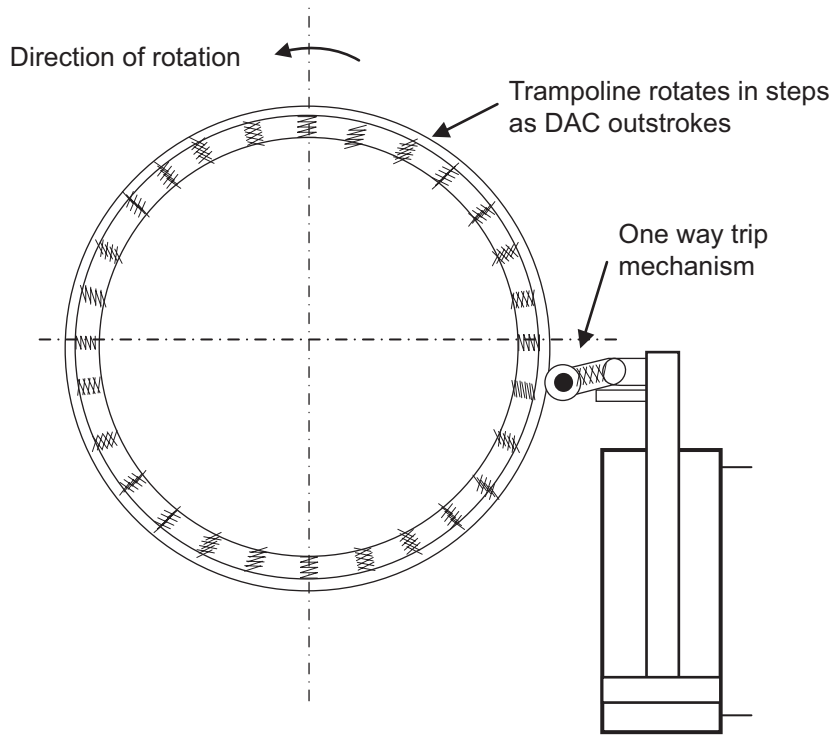

**Not to Scale**

**Fig. 13**



- (d) In order to increase their range of products the company is considering manufacturing the pots using light-emitting polymers.

Briefly explain **one** main characteristic associated with light-emitting polymers and give **one** other specific application.

Main characteristic \_\_\_\_\_  
\_\_\_\_\_ [1]

Application \_\_\_\_\_  
\_\_\_\_\_ [1]

- (e) A review into the work of the company producing the plastic pots made reference to detailed five stage risk assessments and Quality Assurance (QA) procedures.

(i) With reference to a manufacturing process of your choice, briefly outline any **four** stages from the five stage risk assessment.

1. \_\_\_\_\_  
\_\_\_\_\_
2. \_\_\_\_\_  
\_\_\_\_\_
3. \_\_\_\_\_  
\_\_\_\_\_
4. \_\_\_\_\_  
\_\_\_\_\_ [4]

(ii) Briefly outline **two** main characteristics associated with Quality Assurance (QA).

1. \_\_\_\_\_  
\_\_\_\_\_
2. \_\_\_\_\_  
\_\_\_\_\_ [2]

Examiner Only

Marks Remark

(f) With reference to **Fig. 15** below and with the aid of an annotated **exploded drawing** complete the following using the blank A4 pro forma (**answer number 5(f)**):

An appropriate low cost design for a rotating platform that would enable a person to rotate the plastic flowerpot in order for it to face the sunlight.

[6]

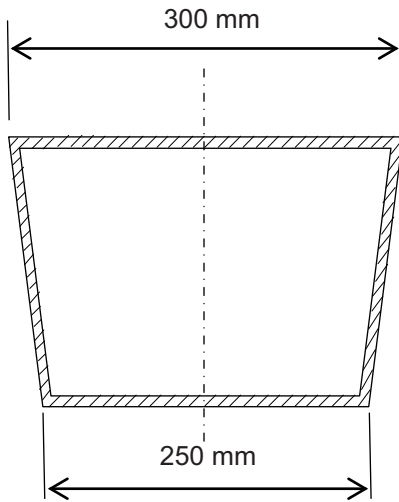

Sectional view of plastic flowerpot



Source © Getty Images

**Fig. 15**

Examiner Only	
Marks	Remark



6 **Fig. 16** shows a photograph of a mobile phone. To improve the sales of this mobile, a phone company is planning a series of shopping centre promotional events. To support these events, phone chargers and holders, t-shirts and other products are to be designed and manufactured.



Source: Principal Examiner

**Fig. 16**

(a) Before creating sketches and ideas for the phone charger, designers used a questionnaire.

Briefly outline **two** main advantages of using a questionnaire for the designers.

1. \_\_\_\_\_  
\_\_\_\_\_
  2. \_\_\_\_\_  
\_\_\_\_\_
- [2]

(b) When generating ideas for the phone charger designers employed design critiques.

Explain what is meant by a design critique.

- \_\_\_\_\_
- \_\_\_\_\_
- \_\_\_\_\_
- \_\_\_\_\_
- [2]

Examiner Only	
Marks	Remark



- (f) In addition to the charger the phone company plans to manufacture a number of t-shirts advertising the company name and logo using dye sublimation.

With the use of an annotated sketch explain the dye sublimation process which could be used to print a logo onto the t-shirts.

[4]

- (g) The phone company also has plans to manufacture a number of low cost plastic phone belt holders to be given out free of charge at promotional events. **Fig. 17** shows a photograph of a typical situation where this design could be used. Using the blank A4 pro forma (answer number **6(g)**) use detailed annotated sketches to produce **one** possible solution for the following:

An appropriate design for a plastic mobile phone holder which can be easily clipped onto a belt. The design must allow the user to quickly attach or remove the holder to or from the belt but ensure that the mobile phone is secure.

[4]

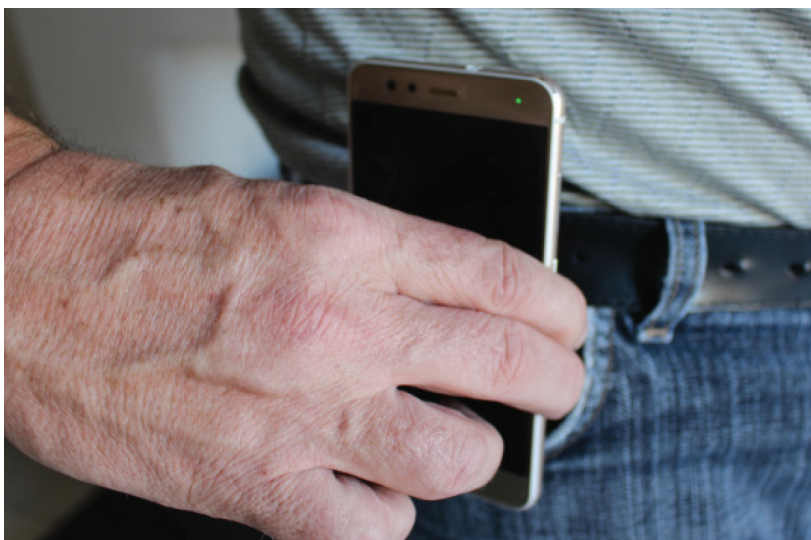

Source: Principal Examiner

Fig. 17

Examiner Only	
Marks	Remark



---

**THIS IS THE END OF THE QUESTION PAPER**

---



Sources

Fig.14 and Fig.15..... © Getty Images

Permission to reproduce all copyright material has been applied for.  
In some cases, efforts to contact copyright holders may have been unsuccessful and CCEA  
will be happy to rectify any omissions of acknowledgement in future if notified.